

See discussions, stats, and author profiles for this publication at: <https://www.researchgate.net/publication/234014091>

# Catania Astrophysical Observatory facility for UV CCD characterization

Conference Paper in Proceedings of SPIE - The International Society for Optical Engineering · October 1996

DOI: 10.1117/12.255998

CITATIONS

17

READS

32

7 authors, including:



**Giovanni Bonanno**

National Institute of Astrophysics

186 PUBLICATIONS 2,429 CITATIONS

SEE PROFILE



**Pietro Bruno**

National Institute of Astrophysics

88 PUBLICATIONS 551 CITATIONS

SEE PROFILE



**Rosario Cosentino**

National Institute of Astrophysics

182 PUBLICATIONS 1,498 CITATIONS

SEE PROFILE



**Rosario Di Benedetto**

National Institute of Astrophysics

14 PUBLICATIONS 164 CITATIONS

SEE PROFILE

Some of the authors of this publication are also working on these related projects:



Muon Portal [View project](#)



ESA PLATO 2.0 Mission [View project](#)

# The Catania Astrophysical Observatory facility for UV CCD characterization

G. Bonanno, P. Bruno, A. Cali, R. Cosentino, R. Di Benedetto,  
M. Puleo, S. Scuderi  
Osservatorio Astrofisico di Catania Viale A. Doria, 6, I-95125 Catania, ITALY

## ABSTRACT

We describe the instrumental apparatus developed at the Catania Astrophysical Observatory to characterize the CCDs detectors for the "Spectrum UV" space observatory. The system allows to perform a full characterization of the electro-optical properties of CCDs. In particular the system is designed to measure the CCDs quantum efficiency (QE) in the wavelength range 1300 – 11000 Å. The main components of the instrumental apparatus are a Deuterium and a Xenon lamp as radiation sources, a monochromator as light disperser, a series of filters to minimize the contribution of the straylight and the second order of the gratings and a series of NIST calibrated photodiodes as reference detectors. For measurements below 2000 Å the system is operated under vacuum conditions. The short wavelength cutoff is due to the use of MgF<sub>2</sub> optics. The CCDs are operated using different CCD controllers, one developed for the Catania Astrophysical Observatory and the other one for the Italian national telescope "Galileo". Here we report on the performances of the instrumental apparatus and also present results on the QE of a CCD chip manufactured by EEV.

## 1. INTRODUCTION

The important motivation that drives the present work is the need of the Italian astronomical community of efficient and reliable detectors in the Ultra Violet spectral region to be used for astronomical space missions.

Present space imaging requirements translate into extremely demanding detectors performances and characteristics such as pixel size, dimension of the sensitive area, noise and quantum efficiency.

The Spectrum-UV mission<sup>1</sup>, an ultraviolet space observatory aboard the Spectrum Series platform, which carries a 170-cm aperture telescope optimized for spectroscopy and imaging in the 912 to 3600 Å range, is one of these missions. As detectors for the instrumentation, large area detectors either photon counting devices or CCDs are required. One of the main activities of our laboratory is the characterization of these kind of devices<sup>2,3,4,5</sup>. In order to better understand the real performances of these detectors in the UV region a new instrumental apparatus has been developed. The system, working under vacuum conditions, allows to perform a full characterization of the electro-optical properties of CCDs, and in general of all available detectors, in the wavelength range 1300 – 11000 Å. The short wavelength cutoff is due to the use of MgF<sub>2</sub> optics.

A complete and accurate characterization is very important to determine the applications in which a detector is better than another.

Here we report on the performances of the instrumental apparatus and also present preliminary results on the QE in the UV region of a thinned back-illuminated coronene coated CCD chip manufactured by EEV. Particular attention has been paid to the effect of vacuum "contaminants" on the CCD quantum efficiency.

## 2. THE INSTRUMENTAL APPARATUS

The instrumental apparatus used for the quantum efficiency measurements has been designed at the Catania Astrophysical Observatory. The system, shown in figure 1, is a modified version of a previous system already operating at the Catania Astrophysical Observatory<sup>6</sup> in the near-UV, optical range. Below  $\sim 2000 \text{ \AA}$  the system has to be operated under vacuum conditions because air absorbs strongly the UV radiation, so along the radiation path from the sources to the detectors, various modules have been built and/or assembled, each performing a different task (e.g. focusing or dispersing the radiation beam). Each module is vacuum sealed and is connected along the radiation path to the next one through a flange. The use of  $\text{MgF}_2$  optics and coated mirrors throughout the whole system yields a good transmittance down to  $1300 \text{ \AA}$ .

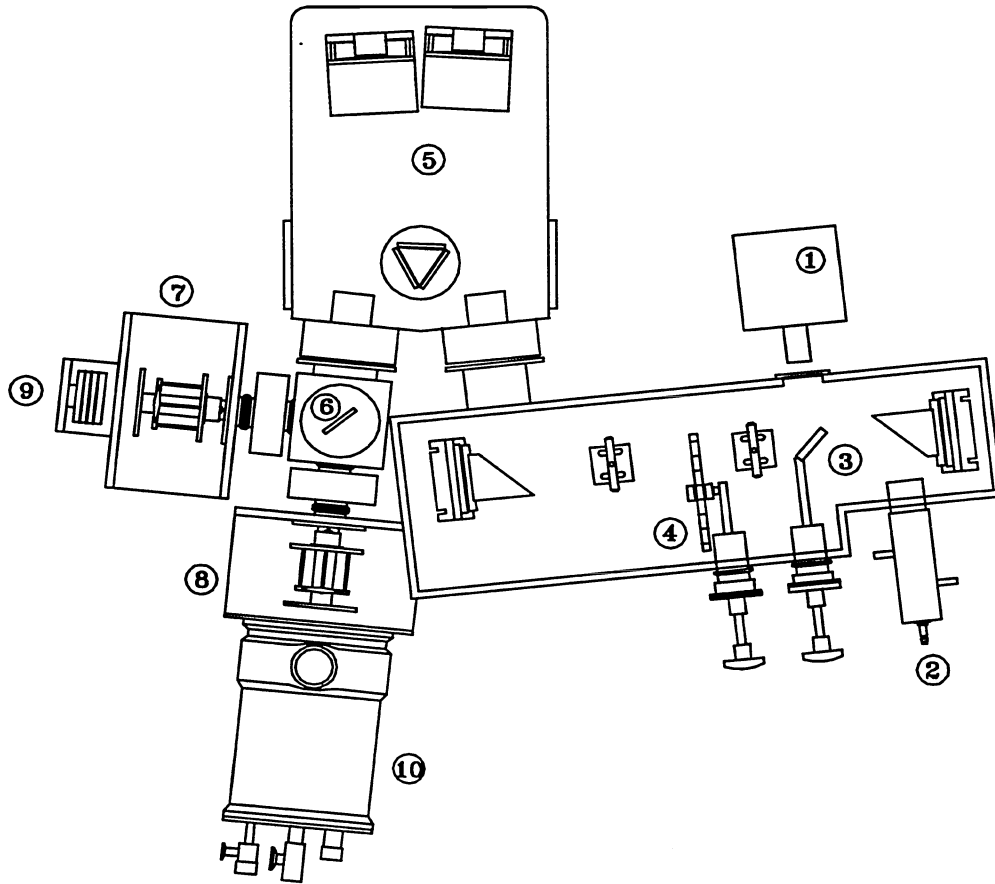

Figure 1 - The experimental set-up: 1) xenon lamp, 2) deuterium lamp, 3) moving plane mirror, 4) filter wheel, 5) monochromator, 6) beam splitter camera, 7) photodiode camera, 8) CCD camera, 9) photodiode, 10) CCD cryostat.

The first module accommodate an optical system, made up of mirrors and diaphragms, whose purpose is to have the beam emitted by the radiation sources matching the  $f/5.4$  focal ratio of the monochromator. The sources are a deuterium lamp and a xenon lamp. The 150 W deuterium lamp is used to cover the  $1300 - 3000 \text{ \AA}$  spectral range. It is sealed with a  $\text{MgF}_2$  window. The emitted beam is focused on the entrance slit of the monochromator by two off-axis paraboloidal mirrors ( $\text{MgF}_2$  coated). A vacuum flange, inserted on the lamp jacket, allows the accommodation of the source inside the module. The xenon lamp covers the remaining spectral range ( $3000 - 11000 \text{ \AA}$ ) of interest. Being used above  $3000 \text{ \AA}$ , the lamp is placed outside the module in front of a sealed quartz window. The parallel beam (the lamp's housing accommodate a system of lens) emitted by the lamp is intercepted by a moving plane mirror and focused on the slit by the second paraboloid. Finally, between the two mirrors there is

a filter wheel which holds interference filters, bandpass filters and longpass filters. Their purpose is to filter out the second order and/or to cut down the contribution of the straylight. The moving plane mirror and the filters wheel are operated by means of vacuum feedthroughs.

The second module along the radiation beam path is the monochromator (model VM504 manufactured by the Acton Research Corporation). It has a Czerny–Turner configuration with a focal length of 0.39 m and an aperture ratio of  $f/5.4$ . The monochromator is equipped with three 1200  $g/mm$  ruled gratings to cover most efficiently the whole spectral range. The entrance and exit slits were both 500  $\mu m$  wide and 1 cm long.

After being dispersed the radiation beam enters a camera containing a  $MgF_2$  beam splitter with a thin film metallic coating (2" diameter). The beam splitter is optimized to transmit and reflect  $\sim 30\%$  of the incident radiation at UV wavelengths.

The reflected and transmitted beams are then focused respectively on the reference detector and on the CCD. This task is performed by two "twins" cameras. The focusing mechanism inside each camera is made up of a magnesium fluoride lens (2" diameter, 75mm focal length) placed on a moving frame. The frame runs along two guides and the movement is driven by a step motor. The mechanism has been realized to compensate the variation of the focal length of the lens with the wavelength allowing to have always a focused image of the monochromator's slit on the detectors. The camera on the direct (*i.e.* transmitted) beam holds also a shutter. These cameras are connected to the beam splitter camera through a gate valve. This expedient allows to switch the reference detector and the CCD while keeping all the system, but the two cameras, under vacuum. As reference detectors we use three different *NIST* calibrated photodiodes: one sealed with a  $MgF_2$  window for the 1300 – 2000 Å range and the other two with a quartz window covering the 2000 – 4000 Å and 4000 – 11000 Å ranges respectively.

The scheme of the pumping system used for vacuum operations is shown in figure 2. We have three turbomolecular pumps and two rotary pumps, used as primary pumps. Two of the turbomolecular pumps are placed directly on the first module and on the monochromator, respectively. They have a pumping speed of 80  $l/s$  (referred to  $N_2$ ). The third turbomolecular pump (pumping speed 200  $l/s$ ) is connected permanently to the "twins" cameras and to the CCD's cryostat when needed. It usually takes up to four or five hours to go from atmospheric pressure down to  $10^{-4} mbar$ . The system is usually operated at  $10^{-5} mbar$ . As we said before when switching the photodiode and the CCD only the "twins" camera go to atmospheric pressure so that the time needed to go back to the starting conditions is a couple of hours.

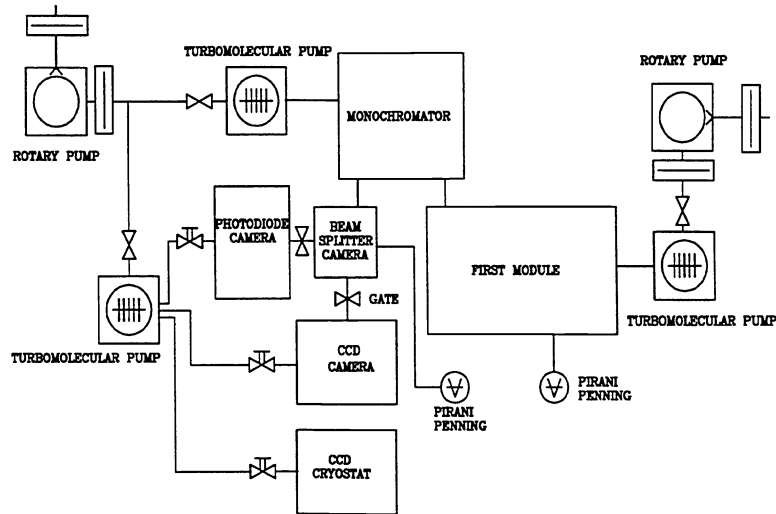

Figure 2 - The scheme of the pumping system.

### 3. THE CCD CONTROLLER

Two CCD controllers have been used to perform the measurements: one developed at the Catania Astrophysical Observatory<sup>7</sup> and another one which is the same developed for the Italian National Telescope "Galileo"<sup>8</sup>. The last one is based essentially on transputers and Digital Signal Processors (DSP). The transputer technology has been adopted to take advantage of their flexible networking and communication scheme, while, to generate fast and synchronous sequencing a dedicated DSP (Motorola 56001) was selected.

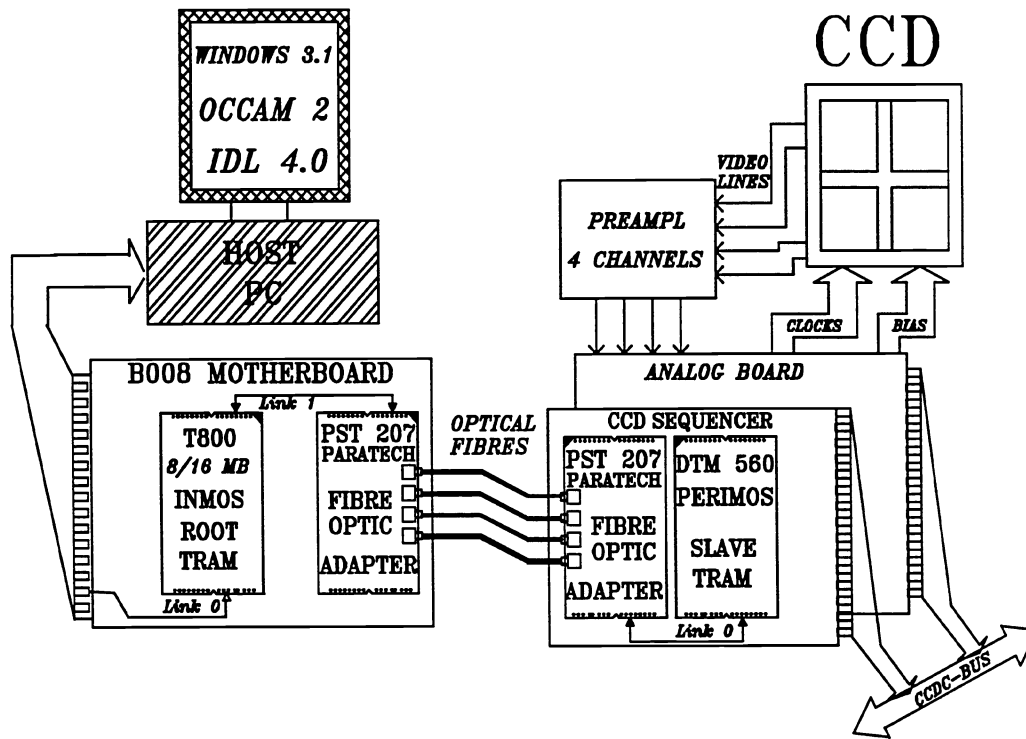

Figure 3 - The CCD controller

The data acquisition system is constituted by two parts: the host PC, that has inside a B008 mother board able to hold various transputer modules and the remote controller. Figure 3 shows the block diagram of the CCD controller. The right part of the figure shows the remote controller: a 4 channel preamplifier located close to the cryostat and two other modules, the analog board and the sequencer. The analog board provides 8 bias voltages and 16 clocks programmable. Telemetry allows the monitoring of these voltages. Furthermore the board can process and convert, in 16 bit data, 4 separate video channels.

The sequencer has 28 independent lines distributed on two ports. The status and the delay loop are generated by an appropriate program running on DSP. Finally the sequencer manages the shutter and the temperature controller. Up to eight different values of temperature can be monitored and two of them can be controlled.

The CCD controller allows different CCD readout modes: a) full frame mode; b) drift scan mode; c) readout of a set of predefined boxes with fast skip of unwanted pixels. Binning during readout is possible for all the above listed modes.

#### 4. THE QUANTUM EFFICIENCY MEASUREMENTS

To show the performances of the instrumental apparatus we have measured the quantum efficiency of a thinned back illuminated coronene coated CCD manufactured by EEV (CCD-02-06 series). As we are mainly interested to the Vacuum UV region the measurements were made below 2500 Å. The measurement the quantum efficiency (QE) is conceptually simple, one has to compare the CCD signal with the signal of a reference detector. As we have shown in the second paragraph the use of the beam splitter allows us to measure the CCD and the photodiode signal simultaneously. Our previous experience<sup>4</sup> showed, in fact, that the flux stability of the radiation sources can be a major problem if the elapsing time between the CCD and the photodiode measurement is quite long, which is what happens when operating under vacuum conditions.

Two preliminary measurements are needed before obtaining the QE of the CCD: a) the measurement of the CCD conversion factor,  $F$ , expressed in  $e/DN$ ; b) the relative calibration between the flux transmitted by the beam splitter and the reflected flux at the wavelengths of interests.

The conversion factor has to be evaluated with good accuracy because of the role it plays in the computation of the photoelectrons. The conversion factor was measured following the technique described in Bonnano et al<sup>2</sup>. We found  $F = 6 \pm 0.5 e/DN$ .

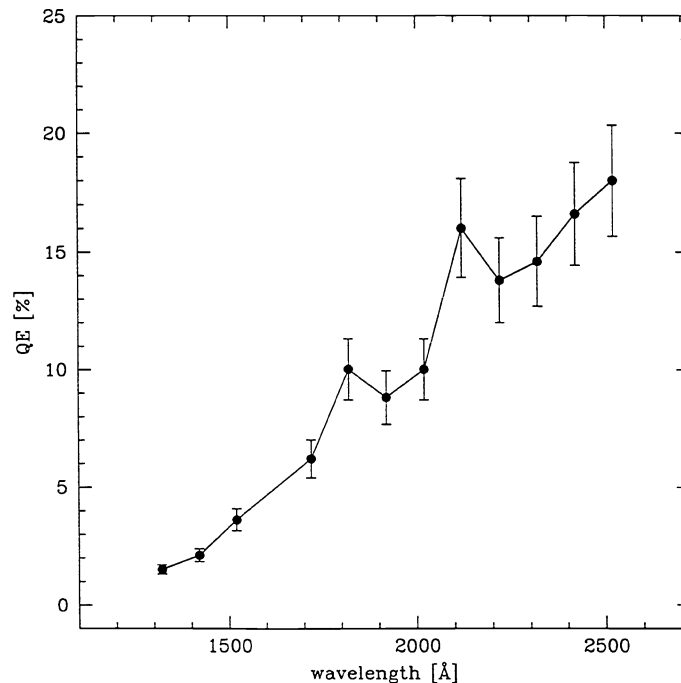

Figure 4 - Quantum Efficiency of the EEV CCD-02-06 in the 1300–2500 Å wavelength region

The relative calibration was performed placing the photodiode first on the reflected beam and then on the transmitted beam. As the CCD dewar is sealed with a  $MgF_2$  window in the measurement of the transmitted flux we introduced along the radiation path another  $MgF_2$  window to simulate the presence of the one in front the CCD. Finally a last series of measurements was done placing the photodiode back again in its normal position to check for variations in the lamp flux. No variation was found.

In figure 4 we have plotted the results of the quantum efficiency measurements. As expected for this kind of CCDs the QE rapidly drops to few per cent going towards wavelengths shorter than 2000 Å where the coronene is not efficient any longer in down-converting the UV radiation and the presence of a “dead layer”, generated by the native oxide layer that forms on the CCD surface after the thinning process, prevents the VUV photons from reaching the collecting region.

The errorbars shown in figure are due mainly to the accuracy of the photodiode calibration ( $\sim 10\%$  at all wavelengths) and to the precision of the conversion factor evaluation.

Finally figure 5 shows an image of the slit of the monochromator taken at  $\lambda=1321$  Å.

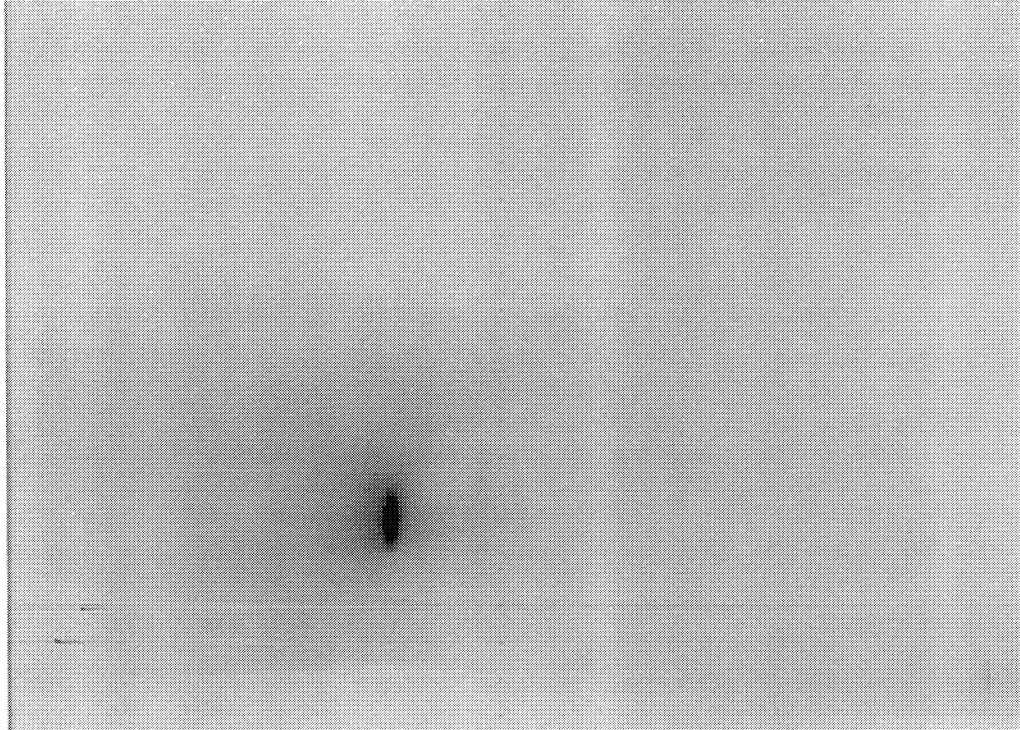

Figure 5 - Image of the monochromator's slit on the CCD EEV-02-06 at  $\lambda = 1321$  Å. The dimensions of the CCD are  $578 \times 385$  pixels with a pixels size of  $22 \mu m^2$ .

## 5. EFFECT OF CONTAMINANTS ON THE QUANTUM EFFICIENCY

During previous measurements we observed a QE decreases with time. Soon after the CCD cooling, higher QE values were found and as time went by, lower values were measured, with the phenomenon being more severe at shorter wavelengths<sup>4</sup>. The same kind of behaviour has been already noticed by Stern et al<sup>10</sup>. The most likely explanation<sup>10</sup> is that the decrease is due to the adsorption on the surface of the CCD, which acts like a small cryopump, of the residual gases present inside the vacuum chamber. In previous measurements<sup>4</sup> the CCD was placed inside a cryostat and connected to the vacuum chamber without any protection, while we preferred to seal the cryostat using a  $MgF_2$  window, thus protecting the CCD from residual gases present in the remaining of the system but not in the dewar. Yet, this partial insulation of the CCD is not enough to prevent the QE decrease as the data plotted in figure 6 clearly show. We monitored the QE behaviour with time at two different wavelengths. At  $\lambda = 2320$  Å the QE is quite stable with time, while at 1320 Å it decreases to  $\sim 50\%$  of the initial value after about 24 hours. The composition of the residual gases inside the dewar shows that the main contribution comes from water vapour (62.9%) with minor percentage of other gaseous species, i.e. OH, 19.6%,

$N_2$ , 7.9% and  $O_2$ , 1.2%. This seems to suggest that the main “contaminant” responsible for the QE degradation is the water vapour that being adsorbed on the CCD’s surface forms a layer which prevents the UV photons from reaching the CCD.

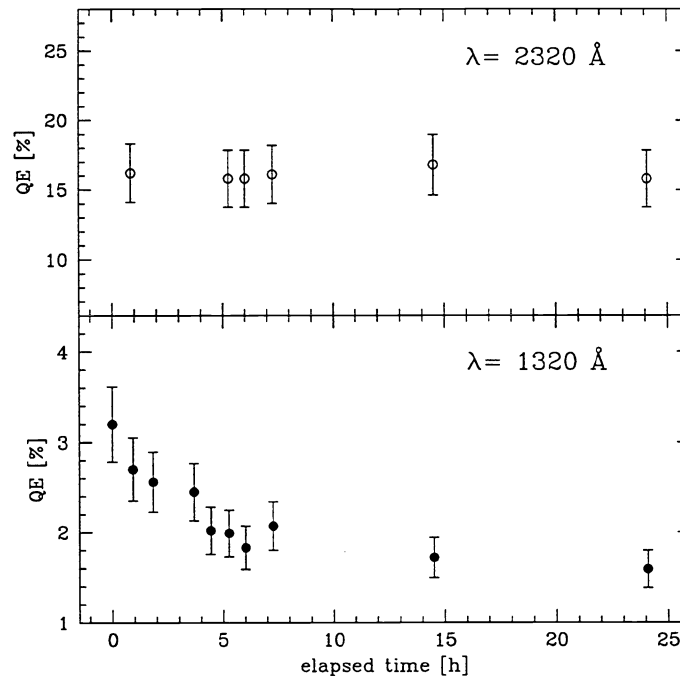

Figure 6 - Temporal behaviour of the QE. The upper panel shows the measurements performed at  $\lambda = 2320 \text{ \AA}$ . In the lower panel the  $\lambda = 1320 \text{ \AA}$  measurements are shown

## 6. CONCLUSIONS

We have presented a new test facility to calibrate detectors in the UV and visible spectral range. The performances of the system have been shown to be very satisfactory. Thanks to the high emitted power of the sources, to the efficiency of selected optics and to the good accuracy of the calibration of the photodiodes it is possible to perform quantum efficiency measurements at good signal-to-noise ratio down to  $1300 \text{ \AA}$ .

As example of the capability of the system we have performed the measurement of the quantum efficiency of an EEV back illuminated coronene coated CCD.

Furthermore the effect of “contaminants”, present inside the vacuum system, on the temporal behaviour of the CCD quantum efficiency has been investigated. The partial insulation of the CCD, placed inside the dewar, does not prevent the pile up of “contaminants” on its surface. The result is the degradation of the QE (stronger at lower wavelengths) with time. Optimization of the cooling and of the vacuum procedures or the design of a new kind of CCD housing are possible solutions to this problem which is still open.

## 7. ACKNOWLEDGMENTS

The project was supported in part by the Agenzia Spaziale Italiana under the Spectrum Ultra Violet Telescope project and in part by the Catania Astrophysical Observatory funds devoted to the detectors activity.



## 8. REFERENCES

- 1) H. Becker-Ross, S. Florek, M. Grewing, N. Kappelmann, G. Kramer, G. Naletto, C. Pernechele, D. Schonberner, E. Tanzi, G. Tondello, "SUV: The Spectrum Ultraviolet Mission, A General Purpose Ultraviolet Observatory", *Proc. SPIE* **2209**, 557-567 (1994).
- 2) G. Bonanno, A. Calì, R. Di Benedetto and S. Scuderi, "Characterization of CCDs with enhanced UV response", *Proc. SPIE* **1743**, 223-234 (1992).
- 3) G. Bonanno, G. Naletto and G. Tondello, "A test facility to calibrate EUV detectors", *ESA Special Publication* **356**, 233-236 (1992).
- 4) G. Naletto, G. Tondello, G. Bonanno, R. di Benedetto and S. Scuderi, "Response analysis in the 300-2500 Å spectral range of UV-enhanced CCDs", *Opt. Eng.* **33** 2544-2552 (1994).
- 5) G. Naletto, G. Tondello, P. Villorosi, G. Bonanno, A. Calì, R. di Benedetto and S. Scuderi, "Comparison between the EUV performances of cryogenically cooled CCDs and a MAMA detector", *Proc. SPIE* **1743**, 199-210 (1992).
- 6) G. Bonanno "New developments in CCD Technology for the UV-EUV spectral range", *IAU 167 Proceedings* 39-48 (1995).
- 7) G. Bonanno, R. Di Benedetto "A CCD Camera for the Echelle Spectrograph at Catania Astrophysical Observatory", *PASP* **102**, 835-841 (1990).
- 8) F. Bortoletto, C. Bonoli, M. D'Alessandro, G. Farisato, G. Bonanno, P. Bruno, R. Cosentino, G. Bregoli, M. Comari, "CCD Cameras for the Italian National Telescope Galileo", *Proc. SPIE* **2654**, 249-258 (1996).
- 9) D.H. Gudehus and D.J. Hegyi, "The design and construction of a charge-coupled device imaging system", *Astr. J.* **90**(1), 130-138 (1985).
- 10) R.A. Stern, R.C. Catura, R. Kimble, M. Winzenread, M.M. Blouke, R. Hayes, D.M. Walton and J.L. Culhane, "Ultraviolet and extreme ultraviolet response of charge-coupled-device detectors", *Opt. Eng.* **26**(9), 875-883 (1987).